



PART NUMBER: L23500

SERVICE INSTRUCTIONS

REVISION			
LTR.	DESCRIPTION	DATE	BY
A	CREATED PER E14565	11/29/04	LFK

FOR MODEL GDR SERIES INDUSTRIAL MOUNTS (E, K, 3, 4, 5, & 6)

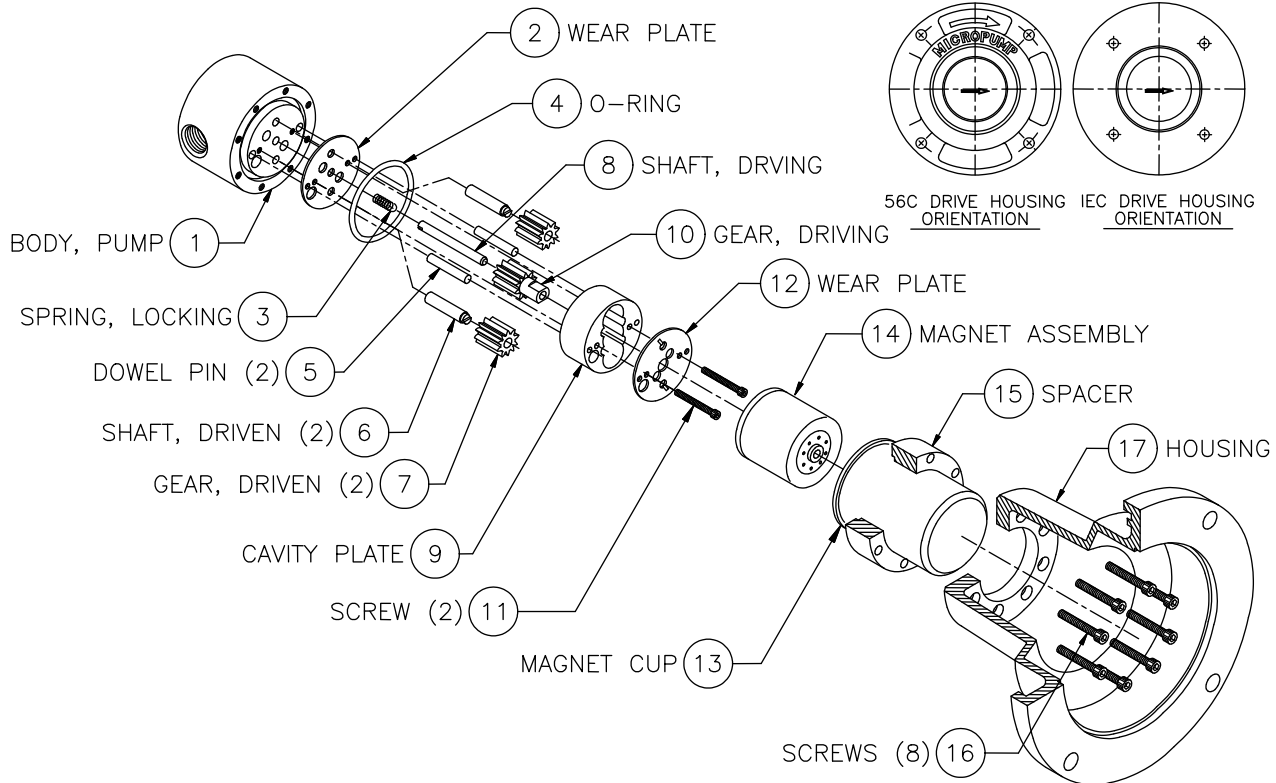

GENERAL:

1. All service work should be performed in a clean area.
2. Care should be taken to avoid scratching any sealing surfaces or allowing metal chips to come in contact with the driven magnet assembly.
3. An even, light coat of high vacuum silicon grease (Dow Corning or equivalent) should be applied to all seals or O-Rings.
4. Seals with chamfer should always be installed with the chamfer up, away from the groove.
5. All assembly screws should be tightened evenly and in an alternating pattern.
6. Only Micropump factory authorized replacement parts should be used when servicing any Micropump products.

SPECIFIC:

1. Engage locking spring (3) half loop in driving shaft (8) slot and rotate shaft/spring assembly clockwise while pressing into pump body (1). Firmly seat spring/shaft assembly into hole.
2. Place wear plate (2) over dowel pins (5) and shafts (6 & 8).
3. Apply a light coat of instrument oil to shafts gears and wear plate.
4. Locate cavity plate (9) on dowel pins (5). Place driving and driven gears on shafts and make sure that gears rotate easily turned by hand.
5. Place wear plate (12) over gears and cavity making sure wear plate is seated flat against cavity. Torque screws (11) evenly to 13±1 in-lbs.
6. Torque screws (16) to 40 in-lbs.

MICROPUMP, INC.

A Unit of IDEX Corporation

PO Box 8975, Vancouver, WA 98668-8975 • Phone: 360/253-2008 • Fax: 360/253-2401

MICROPUMP LIMITED

A Subsidiary of Micropump, Inc.

Howard Road, Eaton Socon, St. Neots, Cambridgeshire, PE 19 8ET England, • Phone: (44) (0) 1480-356600

• Fax: (44) (0) 1480-356300