



PART NUMBER: L23814

SERVICE INSTRUCTIONS: L23814

REVISION			
LTR.	DESCRIPTION	DATE	BY
B	ADD J MOUNT FOR E15370	07/31/07	BC

MODEL 180 - "M" & J MOUNT

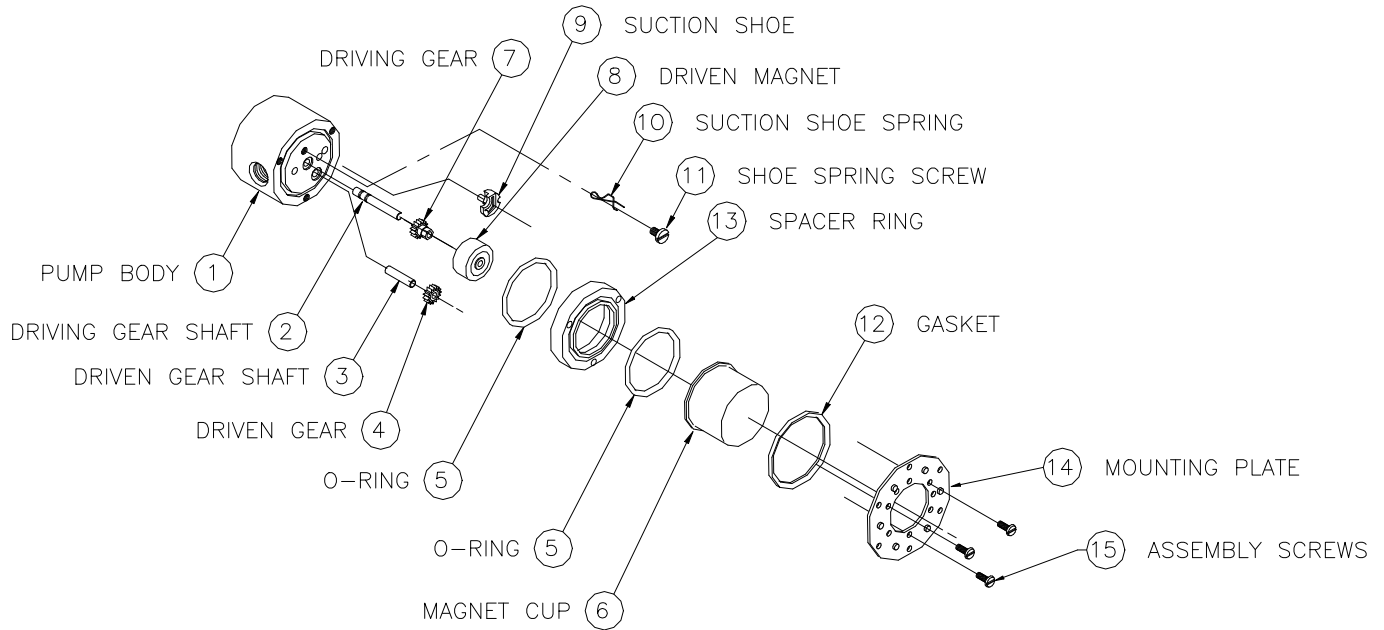

GENERAL:

1. All service work should be performed in a clean area.
2. Care should be taken to avoid scratching any sealing surfaces or allowing metal chips to come in contact with the Driven Magnet Assembly.
3. An even, light coat of high vacuum silicone grease (Dow Corning or equiv.) should be applied to all seals or O-Rings.
4. O-Rings with chamfers should always be installed with the chamfer up, away from the groove.
5. All assembly screws should be tightened evenly and in an alternating pattern.
6. Only Micropump factory authorized replacement parts should be used when servicing any Micropump products.

SPECIFIC:

1. Do not attempt to remove Driving Gear Shaft (2) from Pump Body (1). The Shaft (2) position is preset at the factory. (If replacement of shaft is necessary, pump must be returned to the factory for repair.)
2. Install the Driving Gear (7) and Driven Gear (4) over the Shafts (2 & 3)
3. Install the Suction Shoe (9) and install the Suction Shoe Spring (10) per the spring setting procedure below.
4. Engage the Driven Magnet (8) with Driving Gear (7). Gears and Magnet should rotate freely.
5. Complete assembly as shown above.

MICROPUMP, INC.

A Unit of IDEX Corporation

PO Box 8975, Vancouver, WA 98668-8975 • Phone: 360/253-2008 • Fax: 360/253-8294

MICROPUMP LIMITED

A Subsidiary of Micropump, Inc.

Howard Road, Eaton Socon, St. Neots, Cambridgeshire, PE 19 8ET England, • Phone: (44) (0) 1480-356600 • Fax: (44) (0) 1480-356300

REVISION			
LTR.	DESCRIPTION	DATE	BY
B	ADD J MOUNT FOR E15370	07/31/07	BC

SPRING SETTING PROCEDURE

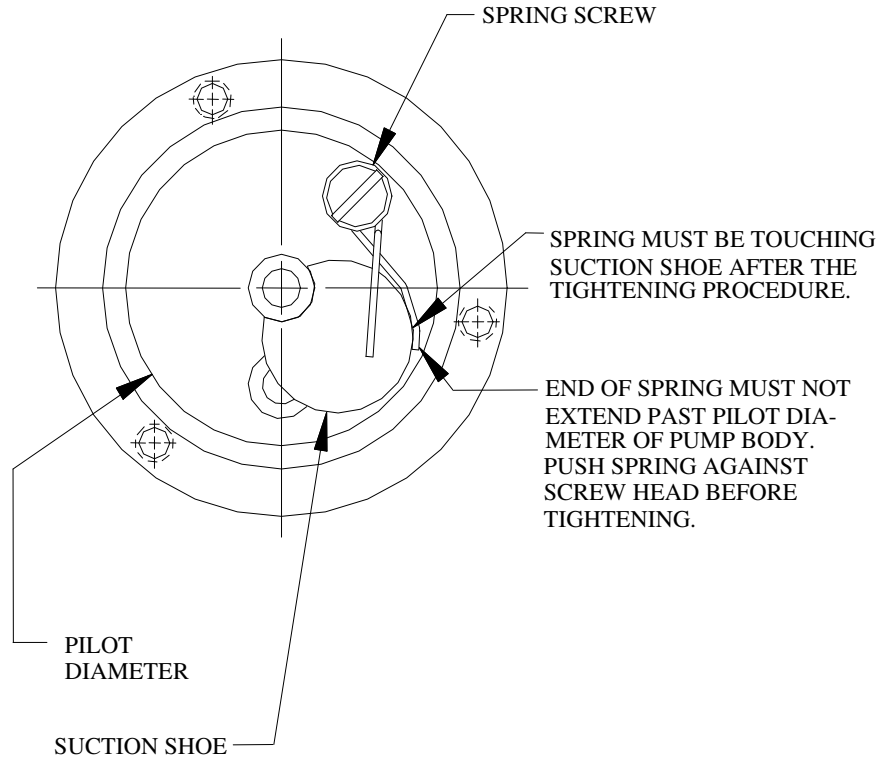

Figure 1
Typical Configuration
(Components may vary depending on application)

1. Place the gears and the suction shoe on the pump body. Affix the spring to the pump body to hold the suction shoe in place. Using screw (11) and suction shoe spring (10), put screw through the end loop in the spring so that the head of the screw is on the same side as the 90 degree bend. Now start the screw into the pump body, but do not tighten.
2. Next, place the top leg of the spring over the top of the suction shoe and the bottom or horizontal leg against the side of the suction shoe. Lightly tighten.
3. Check that the horizontal leg of the suction shoe spring is resting against the side of the suction shoe. Tighten spring screw with spring just touching the suction shoe.
4. Check that the horizontal leg of the spring does not extend past the pilot diameter of the pump body when looking directly down on the suction shoe. (See Figure 1, above). If the spring does extend past the pilot, loosen spring screw and push the spring back towards the screw, and repeat steps 1 and 2.

MICROPUMP, INC.

A Unit of IDEX Corporation

PO Box 8975, Vancouver, WA 98668-8975 • Phone: 360/253-2008 • Fax: 360/253-8294

MICROPUMP LIMITED

A Subsidiary of Micropump, Inc.

Howard Road, Eaton Socon, St. Neots, Cambridgeshire, PE 19 8ET England, • Phone: (44) (0) 1480-356600 • Fax: (44) (0) 1480-356300